

# TIL SALG PÅ 123MC.DK

## SÆLGER



Sydfoyns MC Service  
Møllevvej 19 Ulbølle  
5762 Vester Skerninge

Email [sydfynmc@mail.dk](mailto:sydfynmc@mail.dk)  
Telefon 62241635 / 40377224  
CVR 11524494

## ANNONCE

### 81229-MR5-000 TAPE, PROTECTOR

Ring for pris

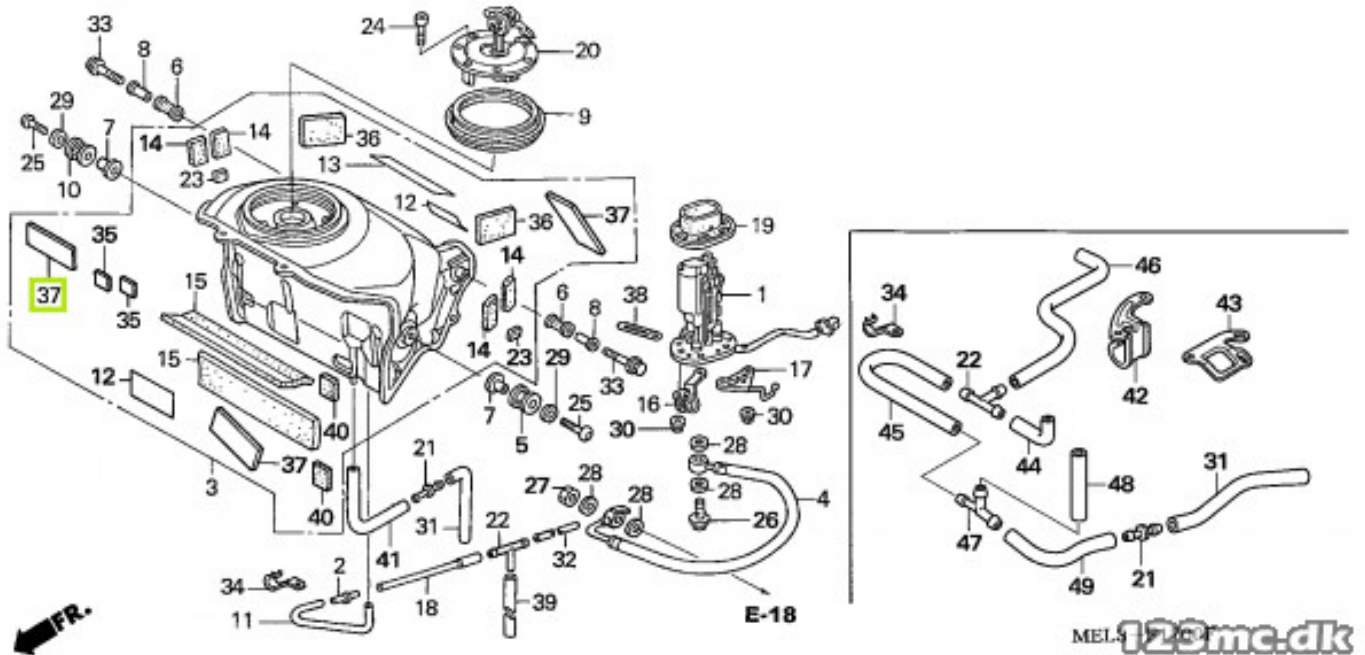

Passer til Honda ST 1100 Pan European

#### Sælgers beskrivelse

Passer til Honda ST 1100 Pan European, Nyt passer på. 1999 ST1100X SP F-19 FUEL TANK 2000 ST1100AY E / ABS F-19 FUEL TANK 2000 ST1100AY ED / ABS F-19 FUEL TANK 2000 ST1100AY G / ABS F-19 FUEL TANK 2000 ST1100AY SP / ABS F-19 FUEL TANK 2000 ST1100PY E / MKH F-19 FUEL TANK 2000 ST1100PY ED / KPH F-19 FUEL TANK 2000 ST1100Y E F-19 FUEL TANK 2000 ST1100Y ED F-19 FUEL TANK 2000 ST1100Y G F-19 FUEL TANK 2000 ST1100Y SP F-19 FUEL TANK 2004 CBR1000RR4 E / KMH F-17 FUEL TANK/FUEL PUMP 2004 CBR1000RR4 ED / KPH F-17 FUEL TANK/FUEL PUMP 2004 CBR1000RR4 F / CMF KPH F-17 FUEL TANK/FUEL PUMP 2004 CBR1000RR4 G / KPH F-17 FUEL TANK/FUEL PUMP 2005 CBR1000RR5 E / KMH F-17 FUEL TANK/FUEL PUMP 2005 CBR1000RR5 ED / KPH F-17 FUEL TANK/FUEL PUMP 1998 ST1100AW SP F-19 FUEL TANK 1998 ST1100W E F-19 FUEL TANK 1998 ST1100W ED F-19 FUEL TANK 1998 ST1100W F F-19 FUEL TANK 1998 ST1100W FI F-19 FUEL TANK 1998 ST1100W G F-19 FUEL TANK 1998 ST1100W SP F-19 FUEL TANK 1999 ST1100AX E / ABS F-19 FUEL TANK 1999 ST1100AX E / ABS 50T F-19 FUEL TANK 1999 ST1100AX ED / ABS F-19 FUEL TANK 1999 ST1100AX ED / ABS 50T F-19 FUEL TANK 1999 ST1100AX G / ABS F-19 FUEL TANK 1999 ST1100AX G / ABS 50T F-19 FUEL TANK 1999 ST1100AX SP / ABS F-19 FUEL TANK 1999 ST1100AX SP / ABS 50T F-19 FUEL TANK 1999 ST1100X E F-19 FUEL TANK 1999 ST1100X ED F-19 FUEL TANK 1999 ST1100X G F-19 FUEL TANK 1996 ST1100T AR F-19 FUEL TANK 1996 ST1100T E F-19 FUEL TANK 1996 ST1100T ED F-19 FUEL TANK 1996 ST1100T G F-19 FUEL TANK 1997 ST1100AV E F-19 FUEL TANK 1997 ST1100AV ED F-19 FUEL TANK 1997 ST1100AV F F-19 FUEL TANK 1997 ST1100AV G F-19 FUEL TANK 1997 ST1100AV SP F-19 FUEL TANK 1997 ST1100V AR F-19 FUEL TANK 1997 ST1100V E F-19 FUEL TANK 1997 ST1100V ED F-19 FUEL TANK 1997 ST1100V G F-19 FUEL TANK 1997 ST1100V IT F-19 FUEL TANK 1997 ST1100V SP F-19 FUEL TANK 1998 ST1100AW E F-19 FUEL TANK 1998 ST1100AW ED F-19 FUEL TANK 1998 ST1100AW G F-19 FUEL TANK 1995 ST1100AS SP F-19 FUEL TANK 1995 ST1100PS E / MKH F-19 FUEL TANK 1995 ST1100PS ED / KPH F-19 FUEL TANK 1995 ST1100S AR F-19 FUEL TANK 1995 ST1100S E F-19 FUEL TANK 1995 ST1100S ED F-19 FUEL TANK 1995 ST1100S F F-19 FUEL TANK 1995 ST1100S G F-19 FUEL TANK 1995 ST1100S SP F-19 FUEL TANK 1996 PC800 F-40 TRUNK LID 1996 ST1100AT E F-19 FUEL TANK 1996 ST1100AT ED F-19 FUEL TANK 1996 ST1100AT F F-19 FUEL TANK 1996 ST1100AT G F-19 FUEL TANK 1996 ST1100AT SP F-19 FUEL TANK 1996 ST1100PT E / MKH F-19 FUEL TANK 1996 ST1100PT ED / KPH F-19 FUEL TANK 1996 ST1100PT SP / KPH F-19 FUEL TANK 1994 ST1100R AR / KPH F-19 FUEL TANK 1994 ST1100R AR / KPH F-19 FUEL TANK 1994 ST1100R E / MKH F-19 FUEL TANK 1994 ST1100R E / MKH F-19 FUEL TANK 1994 ST1100R ED / KPH F-19 FUEL TANK 1994 ST1100R ED / KPH F-19 FUEL TANK 1994 ST1100R F / KPH F-19 FUEL TANK 1994 ST1100R F / KPH F-19 FUEL TANK 1994 ST1100R G / KPH F-19 FUEL TANK 1994 ST1100R G / KPH F-19 FUEL TANK 1994 ST1100R SP / KPH F-19 FUEL TANK 1994 ST1100R SP / KPH F-19 FUEL TANK 1995 ST1100AS E F-19 FUEL TANK 1995 ST1100AS ED F-19 FUEL TANK 1995 ST1100AS F F-19 FUEL TANK 1995 ST1100AS G F-19 FUEL TANK